



# Industrial Carbon Probe

## SIRO<sub>2</sub> ST Probe

Version 1.0, June 2019

**Australian Oxytrol Systems Pty Ltd**

85 Wood Street,  
California Gully VIC 3556  
Australia

**P** + 61 3 5446 1530

**F** + 61 3 5446 1215

**W** [www.australianoxytrolsystems.com](http://www.australianoxytrolsystems.com)

**E** [info@australianoxytrolsystems.com](mailto:info@australianoxytrolsystems.com)



## Contents

<b>1 Description</b>	<b>3</b>
<b>2 Specifications</b>	<b>4</b>
<b>3 Installation</b>	<b>5</b>
<b>4 Installation Fittings</b>	<b>6</b>
<b>5 General Measurement Setup</b>	<b>7</b>
5.1 General Setup	7
<b>6 Thermocouple interface</b>	<b>9</b>
<b>7 Thermocouple ranges</b>	<b>10</b>
<b>8 Sensor Interface</b>	<b>10</b>
<b>9 Theory of operation</b>	<b>11</b>
<b>10 Example calculations and error propagation</b>	<b>12</b>
10.1 Calculating voltage (for calibrated gases)	12
10.2 Calculating oxygen concentration (for measured EMF readings)	12
10.3 Error propagation rules	13
10.4 A table of typical emf readings for various inert gases	13
10.5 Consideration of sensor impedance	14
10.6 Example of measurement error	15
10.7 Response time with respect to gas changes	16
10.8 Reducing measurement noise	16
10.9 Lambda Point for control	17
<b>11 Ordering information</b>	<b>18</b>
<b>12 Probe Length guide</b>	<b>19</b>
<b>13 Contact information</b>	<b>20</b>
<b>14 Australian Oxytrol Systems Pty Ltd one (1) year limited warranty</b>	<b>21</b>
14.1 Introduction	21
14.2 Specific Warranty obligations	21
14.3 Warranty exclusions and limitations	21
14.4 Important!	22
14.5 Obtaining Warranty Service	22

# SIRO<sub>2</sub> ST Probe

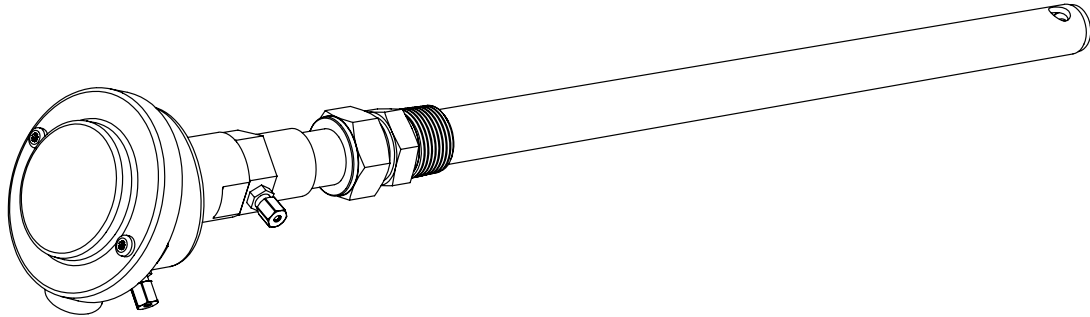

## 1 Description

The ST carbon probe incorporates a SIRO<sub>2</sub> all ceramic oxygen sensor. The probe comes with a 25mm Inconel sheath for extended life and additional protection. It is used for measurement and control of oxygen sensitive environments at high temperatures. The sensor operates in situ, and measures oxygen concentration in real time, without the need for expensive gas sampling, or gas extraction equipment.

### Features

- Specific for O<sub>2</sub>
- High O<sub>2</sub> sensitivity and selectivity
- High dynamic range of detection
- High temperature of operation
- Rapid responses
- In situ measurement
- Solid state electronic component – rugged sensor
- No power consumed for operation under all conditions
- No bias required to operate
- Available up to 1350 mm

### Applications

- Carburising furnace control
- Metal heat treatment processes
- Fuel combustion efficiency control
- Industrial applications
- Furnace gas analysis
- Temperature and oxygen control of kilns
- Annealing furnaces
- Large and small electric kilns
- CO<sub>2</sub> harsh environments

## 2 Specifications

Thermal				
Parameter	Minimum	Typical	Maximum	Unit
Operating temperature	700	950	1100	°C
Operating temperature	1292	1742	2012	°F
Control head operating temperature	—	60	80	°C
Ramp rate	—	—	400	°C/hour
Storage	5	20	80	°C
Electrical				
Parameter	Minimum	Typical	Maximum	Unit
Output voltage range	2.0	1130	1400††	mV @ T ≥ 700 °C
Output impedance	1.00	2.00	10.00	kΩ @ T ≥ 700 °C
Response time	10	20	10000	ms @ T ≥ 700 °C
Offset Error @ 700°C **	0	±2	—	mV @ pO <sub>2</sub> =pO <sub>2</sub> '
Measurement Range				
Parameter	Minimum	Typical	Maximum	Unit
O <sub>2</sub> Atmosphere	10 <sup>-24</sup>	—	1	pO <sub>2</sub> @ 700 °C
Reference air	1	10	20	mL/min
Gas Seal				
Parameter	Minimum	Typical	Maximum	Unit
Gas tight - pressure	—	1	2	atm
Gas tight - pressure	—	100	200	kPa
Sheath Mechanical Inconel 600				
Parameter	Minimum	Typical	Maximum	Unit
Outer Diameter	—	25.0	—	mm
Probe length	650	—	1350	mm ±3 mm
Weight	1	—	5	kg
Electrical Connections				
Description	Pin No	Type	Wiring (internal)	
Thermocouple positive leg	1	Output	Black (thermocouple + )	
Thermocouple negative leg	2	Output	Red (thermocouple — )	
Sensor internal (reference) connection	3	Output	Blue (O <sub>2</sub> , sense-reference)	
Sensor external (sense) connection	4	Output	Grey (O <sub>2</sub> , sense-chamber)	
Connector				
Mating connector	Manufacturer	Part Number		
4 Pin male XLR	Switchcraft	QG4M		

†† Under some conditions, an output voltage of 1650 mV may be observed.

\*\* Offset error should be subtracted from the voltage reading during measurements for high accuracy applications. Also, note that this offset value is temperature dependent.

The sensor within a probe can be installed anywhere in the kiln or furnace if used at temperatures below 1093°C.

### 3 Installation

The ST probe must not be handled by the probe head.

The sheathed ST probe must be handled by the Inconel sheath with no weight or force applied to the head assembly. Two hands should be applied at the quarter mid-points of the sheath. Carefully insert the probe into the furnace aperture. Once the probe has been inserted the instrument interface cable and reference air may then be connected. The ST-1200-R-BSPT is shown below installed into a furnace having a wall thickness of 750 mm.

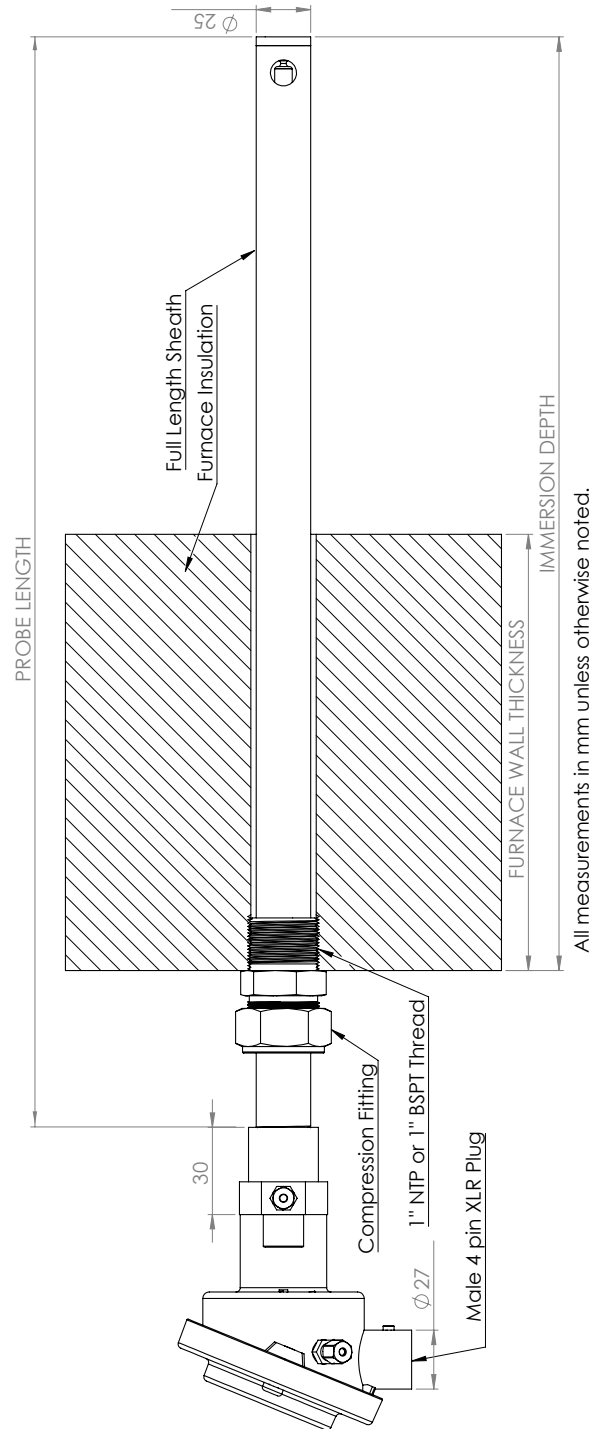

## 4 Installation Fittings

The probe is shipped with a compression fitting, either a BSPT or NPT thread. This option must be selected when ordering.

**BSPT fitting**

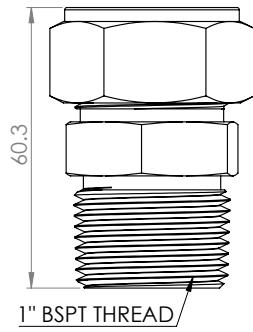

**NPT fitting**

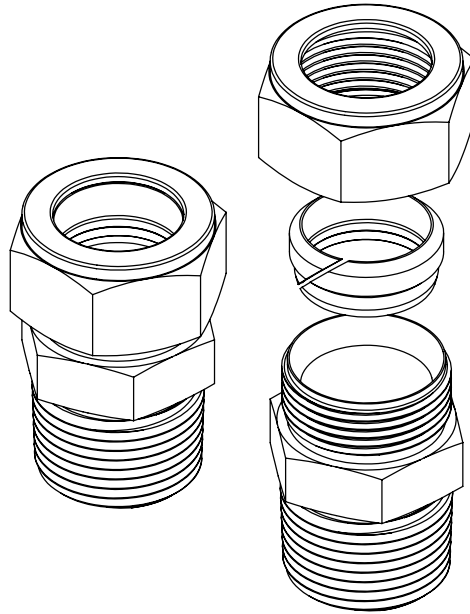
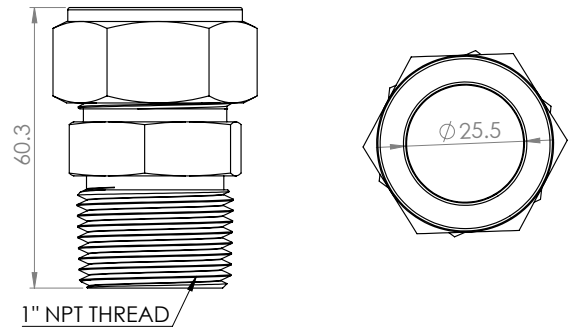

## 5 General Measurement Setup

Key to accurate measurements of the oxygen concentration of the gaseous environments is the measurement setup, namely:

1. Probe location;
2. Electrical interface;
3. Measurement instrumentation;
4. Reference air and air flow rate.

### 5.1 General Setup

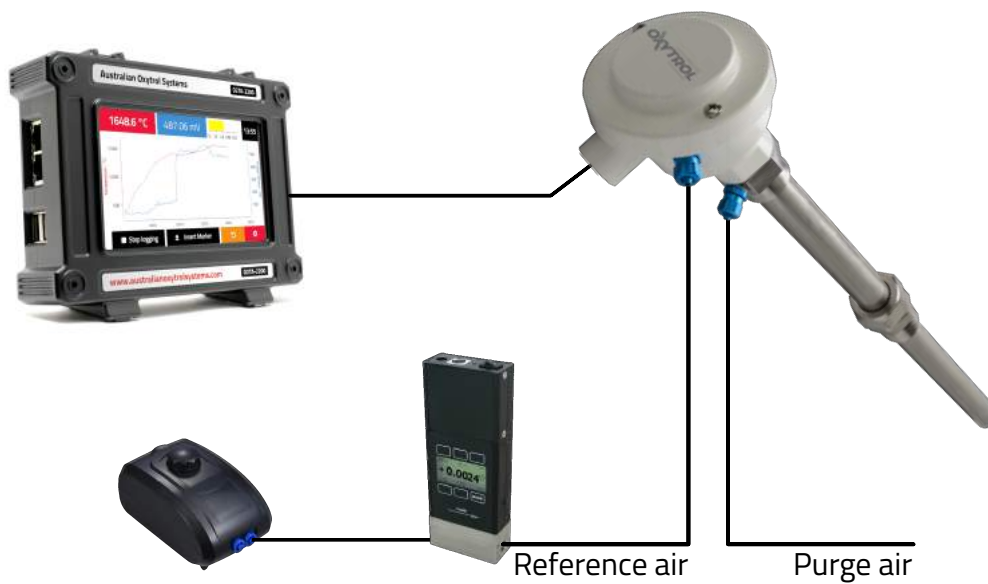

Ideal electrical interface to the probe will have the following characteristics, and include a diaphragm air pump to supply the clean reference air.

Oxygen Sensor Measurement Instrument		
Parameter	Typical	Unit
Ideal input impedance	1	TΩ
Input voltage range	± 2000	mV
Filter	50 – 60	Hz
Thermocouple Measurement Instrument		
Parameter	Typical	Unit
Ideal input impedance	10	MΩ
Input voltage range	± 100	mV
Filter	50 – 60	Hz

- Probe location

In all systems monitoring oxygen concentrations of gases in high temperature environments, the probe sensor needs to be located as close as possible to where the gas reaction is occurring. This means that the probe length needs to accommodate the distance from the outside of the kiln wall, through the thermal insulation, to the point of measurement.

- Electrical interface

The electrical interface between the probe and measurement equipment can be a source of noise. This noise can result in erroneous readings. When ordering your STprobe, it is important to select the correct compensation cable for the thermocouple used in the probe. For example, when a probe uses a K-type thermocouple, the interface cable between the measurement equipment and the probe should be a K-type compensation or extension cable. Similarly, in the heat treatment industry, an R- or S-type thermocouple is used, in which case an R-type compensation or extension cable should be used. Australian Oxytrol Systems can supply K- or R-type thermocouple compensation cable, complete with reference air conduit and twisted pair for connection to the oxygen sensor.

- Measurement instrumentation

Measurement instruments are intended to provide signal analysis that is representative of the signals without modifying the signal characteristics, as much as possible. In a perfect measurement world, the measurement instrument would have an infinite input impedance, and an infinite input frequency response. This means that the measurement instrument or device would have zero influence on the measured signal.

In reality, the measurement instrument will have an input impedance and a frequency response that may not truly reflect the nature of the signal. When making measurements, it is therefore important to understand the influence of the input impedance and frequency response of the measurement equipment. Australian Oxytrol Systems manufactures and supplies patented probe reading equipment for such applications. For more information on this equipment, please contact Australian Oxytrol Systems directly.

- Reference air and flow rate

Clean reference air is essential. A key metric of reference air cleanliness is that it is breathable by people. If the air is contaminated, then it cannot be used as the reference air. The reference air flow rate should be within the range stipulated in Specification section.



## 6 Thermocouple interface

Connecting the thermocouple to instrumentation must be done with consideration to optimize accuracy and, ensure unwanted noise does not appear in the measurement process. The resultant temperature measurement is only as accurate as the sensor and its interface.

The thermocouple produces a small thermo-electric electromotive force (emf), typically  $40 \text{ V}/^\circ\text{C}$  and it is necessary to minimize spurious thermal emf signals and ohmic effects which would otherwise result in incorrect readings.

The length of cable used between the sensor and the instrument is an important consideration because the line resistance has to be taken into account (although the instrument input is effectively high impedance, typically  $1 \text{ M}\Omega - 10 \text{ M}\Omega$ ). Most instruments specify a maximum of  $100 \Omega$  loop cable resistance without accuracy being compromised.

With long cable runs, the cable may need to be screened and earthed at one end (at the instrument) to minimize noise pick-up (interference) on the measuring circuit.

An extension cable uses true thermocouple wire and is designated X (e.g. KX for type K); compensation cable has a C designation (e.g. KC for VX, type K) and consists of VX and U types. An extension cable should be selected for its temperature and electromotive force relationship to an appropriate standard over the complete temperature range, for the thermocouple used. This cable can then be used for joining thermocouples to their measuring instruments.

Compensating cable, which uses lower cost alloys, has a different composition to an extension cable but still having a similar temperature versus electromotive force relationship, but only over a limited environmental temperature range. Therefore, compensating cables should only be used for short distances to connect thermocouples to their measuring instruments. Due to these differences in electromotive force generated for temperatures in contrast to thermocouple voltages, these cables cannot be used at temperatures above ambient. This means that care must be taken to ensure the entire electrical connection from the probe to the measurement device is at ambient. For example, the temperature at the probe head connector can be higher than ambient, and so this will cause a voltage to be generated in the compensating cable that can influence the overall voltage measured by the instrumentation, and so result in an error in actual temperature reading.

Direct connection is made using an appropriate type of cable; this is indicated by colour coding according to IEC 584-3 on the insulation. Correct polarity and a mechanically sound connection is vital.

Compensation and extension cables should be used for all measurements with thermocouples. The reference air and compensation or extension cables are available on request, and are quoted for separately. Standard shielded signal cable can be used for interfacing the oxygen sensor to the measurement instruments. For best performance, the measurement made should be using differential inputs to the instrument to remove unwanted common mode noise.

Australian Oxytrol Systems supplies interface cable that supports the following connections:

- (i) R or K type compensation cable
- (ii) Electrical interface for  $\text{O}_2$  sensor
- (iii) Reference air

## 7 Thermocouple ranges

Type†	Temperature Range		Tolerances-Reference			
	°C	°F	Standard Tolerances		Special Tolerances	
	°C	°F	°C	°F	°C	°F
T	-200 to 0	-328 to 32	± 1.0 or ± 1.5 %		††	
T	0 to 370	32 to 700	± 1.0 or ± 0.75 %	Note 1	± 0.5 or 0.4 %	Note 1
J	0 to 760	32 to 1400	± 2.2 or ± 0.75 %			
E	-200 to 0	-328 to 32	± 1.7 or ± 1 %		††	
E	0 to 870	32 to 1600	± 1.7 or ± 0.5 %		± 1.0 or 0.4 %	
K	-200 to 0	-328 to 32	± 2.2 or ± 2 %		††	
K or N	0 to 1260	32 to 2300	± 2.2 or ± 0.75 %		± 1.1 or 0.4 %	
R or S	0 to 1480	32 to 2700	± 1.5 or ± 0.25 %		± 0.6 or ± 0.1 %	
B	870 to 1700	1600 to 3100	± 0.5 %		± 0.25 %	
C	0 to 2315	32 to 4200	± 4.4 or ± 1 %			

† K and R type thermocouples are standard options for probes.

†† Special tolerances for temperatures below 0°C are difficult to justify, values for Type E and T thermocouples are suggested as a guide.

Type E (-200 to 0) °C ± 1 °C or ± 0.5 %, whichever is greater

Type T (-200 to 0) °C ± 0.5°C or ± 0.8 %, whichever is greater

Note 1: The Fahrenheit tolerance is 1.8 times larger than the °C tolerance at the equivalent °C temperature. Note particularly that percentage tolerance applies only to temperatures expressed in °C.

## 8 Sensor Interface

The instrument interfacing to the sensor should support positive and negative voltage polarities, with the measurement instrument having a high input impedance, typically TΩ. For best performance, the measurement made should be using differential inputs to the instrument to remove unwanted common mode noise.

## 9 Theory of operation

The zirconia-based pellet in the sensor is an oxygen ion conducting solid electrolyte. When the sensor is exposed to different partial pressures of oxygen, across the internal and external faces, an electromotive force is produced. The generated electromotive force follows the Nernst equation:

$$E = \frac{RT}{4F} \ln \left( \frac{pO_2}{pO'_2} \right)$$

- $E$  is the electromotive force as a voltage (V);
- $T$  is the temperature in degrees Kelvin;
- $pO'_2$  partial pressure of oxygen in reference air (inside sensor);
- $pO_2$  partial pressure of oxygen in test gas (outside sensor);
- $F$  Faraday's constant  $96485 \text{ C mol}^{-1}$ ;
- $R$  Gas constant  $8.3145 \text{ JK}^{-1}\text{mol}^{-1}$ .

The reference partial pressure of gas is 20.9 %, making  $pO'_2=0.209$ . Note, COF's convention is for reducing atmospheres ( $pO_2 < 0.209$ ) to result in a negative  $E$  value. Rearranging for the partial pressure of oxygen external to the reference partial pressure of oxygen:

$$pO_2 = pO'_2 e^{\frac{4FE}{RT}}$$

The source impedance of the sensor is subject to the temperature of operation, and varies subject to gas conditions, temperature and reference air. The sensor impedance varies, presenting as an open circuit when cold;  $M\Omega$  at low temperatures;  $k\Omega$  at operating temperatures of  $700^\circ\text{C}$  and above. The operating impedance has a range subject to manufacturing tolerances, and can be seen as a distribution below ( $700^\circ\text{C}$ ).

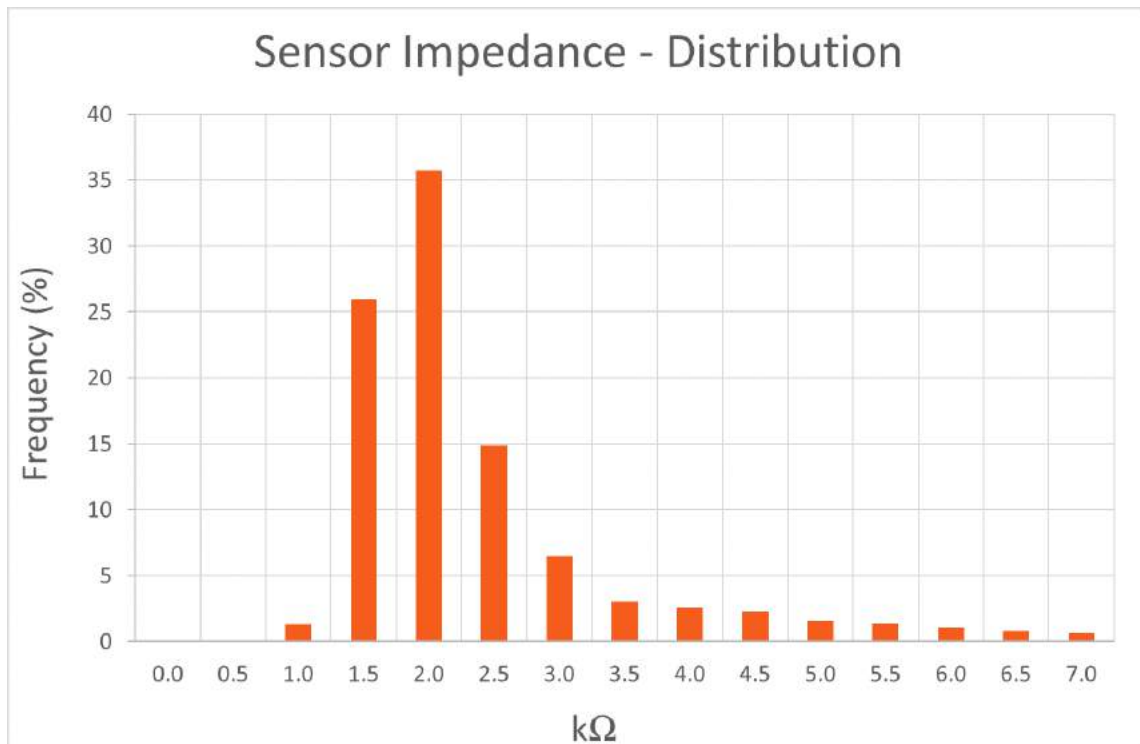

## 10 Example calculations and error propagation

### 10.1 Calculating voltage (for calibrated gases)

Using the Nernst equation to calculate sensor output voltage with respect to known oxygen concentration.

$$E = \frac{RT}{4F} \ln \left( \frac{pO_2}{pO'_2} \right)$$

- $E$  is the electromotive force as a voltage (V);
- $T$  is the temperature in degrees Kelvin;
- $pO_2$  partial pressure of oxygen outside;
- $pO'_2$  partial pressure of oxygen inside;
- $F$  Faraday's constant  $96485 \text{ C mol}^{-1}$ ;
- $R$  Gas constant  $8.3145 \text{ JK}^{-1}\text{mol}^{-1}$ .

Using the following values:

1. Kiln temperature measured by the probe is  $700^\circ\text{C}$ ;
2. Partial pressure of  $O_2$  in reference air of 0.2095 (or 20.95%)<sup>†</sup>;
3. Measurement air to have 1 % oxygen concentration (partial pressure of 0.01);
4.  $E$  is the unknown component.

<sup>†</sup> Since the partial pressure of reference air (oxygen inside) and measurement air (oxygen outside) concentrations are taken as a ratio, this ratio becomes dimensionless.

$$E = \frac{RT}{4F} \ln \left( \frac{pO_2}{pO'_2} \right)$$

The above can now be written as follows:

$$E = \frac{8.3145 \text{ JK}^{-1}\text{mol}^{-1} (700^\circ\text{C} + 273.15)}{4.96485 \text{ Cmol}^{-1}} \ln \left( \frac{0.01}{0.2095} \right)$$

$$E = -0.063768 \text{ V} \text{ or } E = -63.768 \text{ mV}$$

### 10.2 Calculating oxygen concentration (for measured EMF readings)

Rearranging the Nernst equation to calculate oxygen concentration from the sensor output, as a measured millivolt reading.

$$pO_2 = pO'_2 \cdot e^{\frac{E \cdot 4F}{RT}}$$

Using the following known values:

1. Kiln temperature measured by the probe is  $700^\circ\text{C}$ ;
2. Partial pressure of  $O_2$  in reference air of 0.2095 (or 20.95%)<sup>†</sup>;
3.  $E$  is the known component,  $E = -0.063768 \text{ V}$  (as measured);
4.  $pO_2$  is the unknown component.

$$= 0.2095 \cdot e^{\frac{-0.063768 \cdot 4 \cdot 96485 \text{ Cmol}^{-1}}{8.3145 \text{ JK}^{-1}\text{mol}^{-1} \cdot (700^\circ\text{C} + 273.15)}}$$

$$pO_2 = 0.01 \text{ or } 1\% \text{ concentration}$$

### 10.3 Error propagation rules

The following error propagation rules may be applied to the calculations to obtain uncertainties.

$$f = A \cdot B \quad \sigma_f^2 \approx f^2 \cdot \left[ \left( \frac{\sigma_A}{A} \right)^2 + \left( \frac{\sigma_B}{B} \right)^2 + 2 \frac{\sigma_{AB}}{AB} \right]$$

$$f = \frac{A}{B} \quad \sigma_f^2 \approx f^2 \cdot \left[ \left( \frac{\sigma_A}{A} \right)^2 + \left( \frac{\sigma_B}{B} \right)^2 - 2 \frac{\sigma_{AB}}{AB} \right]$$

$$f = aA^b \quad \sigma_f^2 \approx \left( \frac{fb\sigma_A}{A} \right)^2$$

$$f = \ln(bA) \quad \sigma_f^2 \approx \left( a \frac{\sigma_A}{A} \right)^2$$

### 10.4 A table of typical emf readings for various inert gases

Molar/Volume % O <sub>2</sub> in Inert Gas (eg Nitrogen). EMF values are negative mV					
Temperature	1% O <sub>2</sub> in N <sub>2</sub>	5% O <sub>2</sub> in N <sub>2</sub>	Industrial N <sub>2</sub>	HP N <sub>2</sub>	UHP N <sub>2</sub>
°C / (F)	1% ± 0.02%	5% ± 0.08%	10ppm ± 1ppm	2ppm ± 0.1ppm	0.1ppm ± 0.05ppm
600 / (1112)	56.80 - 57.56	26.60 - 27.21	185.31 - 189.09	216.46 - 218.35	266.10 - 286.77
650 / (1202)	60.06 - 60.85	28.13 - 28.76	195.93 - 199.92	228.86 - 230.85	281.34 - 303.19
700 / (1292)	63.31 - 64.15	29.65 - 30.32	206.54 - 210.75	241.25 - 243.35	296.58 - 319.61
750 / (1382)	66.56 - 67.44	31.18 - 31.88	217.15 - 221.57	253.65 - 255.86	311.82 - 336.03
800 / (1472)	69.81 - 70.74	32.70 - 33.44	227.76 - 232.40	266.04 - 268.36	327.05 - 352.45
850 / (1562)	73.07 - 74.04	34.22 - 35.00	238.37 - 243.23	278.44 - 280.86	342.29 - 368.87
900 / (1652)	76.32 - 73.33	35.75 - 36.55	248.99 - 254.06	290.84 - 293.37	357.53 - 385.29
950 / (1740)	79.57 - 80.63	37.27 - 38.11	259.60 - 264.89	303.23 - 305.87	372.77 - 401.72
1000 / (1832)	82.83 - 83.92	38.79 - 39.67	270.21 - 275.71	315.63 - 318.37	388.01 - 418.14
1050 / (1922)	86.08 - 87.22	40.32 - 41.23	280.82 - 286.54	328.02 - 330.88	403.24 - 434.56
1100 / (2012)	89.33 - 90.52	41.84 - 42.79	291.43 - 297.37	340.42 - 343.38	418.48 - 450.98
1150 / (2102)	92.58 - 93.81	43.36 - 44.34	302.05 - 308.20	352.81 - 355.88	433.72 - 467.40
1200 / (2192)	95.84 - 97.11	44.89 - 45.90	312.66 - 319.03	365.21 - 368.38	448.96 - 483.82
1250 / (2282)	99.09 - 100.40	46.41 - 47.46	323.27 - 329.85	377.60 - 380.89	464.20 - 500.24
1300 / (2372)	102.34 - 103.70	47.93 - 49.02	333.88 - 340.68	390.00 - 393.39	479.43 - 516.67
1350 / (2462)	105.60 - 106.99	49.46 - 50.58	344.49 - 351.51	402.40 - 405.89	494.67 - 533.09
1400 / (2552)	108.85 - 110.29	50.98 - 52.13	355.10 - 362.34	414.79 - 418.40	509.91 - 549.51
1450 / (2642)	112.10 - 113.59	52.50 - 53.69	365.72 - 373.17	427.19 - 430.90	525.15 - 565.93
1500 / (2732)	115.35 - 116.88	54.03 - 55.25	376.33 - 383.99	439.58 - 443.40	540.39 - 582.35
1550 / (2822)	118.61 - 120.18	55.55 - 56.81	386.94 - 394.82	451.98 - 455.91	555.63 - 598.77
1600 / (2912)	121.87 - 123.47	57.07 - 58.37	397.55 - 405.65	464.37 - 468.41	570.86 - 615.19

#### Notes

- Please note that other impurities such as CO, CO<sub>2</sub>, H<sub>2</sub>, H<sub>2</sub>O, CH<sub>4</sub>, etc. may also have an effect on the emf
- Values given are a guide only and dependent on gas suppliers, please refer to your own certificate of analysis for O<sub>2</sub> impurity content and uncertainties
- HP is High Purity
- UHP is Ultra-High Purity

## 10.5 Consideration of sensor impedance

Sensor conductance has an Arrhenius relationship with temperature. Impedance as a function of temperature is an important consideration from the following perspectives:

1. Measurement equipment input impedance;
2. Response time of sensor to gas changes;
3. Electrical noise as observed by the measurement system.

Sensor impedance is an important consideration when interfacing to measurement equipment. The lower the temperature the more influence the measuring equipment input impedance has on the measured signal. Namely, if the input impedance of the measurement equipment is not sufficiently high, errors in signal measurement may fall into unacceptable bounds with respect to measurement uncertainties. In short, the input impedance of the measurement equipment should not load the measured signal.

## 10.6 Example of measurement error

Using the following values:

- Kiln temperature measured by the probe is 350 °C;
- Partial pressure of reference air 0.2095;
- Reference gas that has a 1 % oxygen concentration ( $pO_2 = 0.01$ );
- E is the unknown component.

Using the Nernst equation, we calculate a sensor output voltage of  $E = -40.830$  mV. The impedance derived from both the plot above and the interpolation, yields a signal source impedance of  $1.2\text{ M}\Omega$ . Using an instrument with an input impedance of  $1\text{ M}\Omega$ , the actual measured voltage is calculated as follows, using the known components:

- Kiln temperature measured by the probe is 350 °C;
- Sensor voltage output should be,  $V = -40.830$  mV;
- Impedance of sensor at 350 °C is  $R_S = 1.2\text{ M}\Omega$ ;
- Instrument input impedance  $R_M = 1.0\text{ M}\Omega$ ;  $V_M$  is the voltage measured.

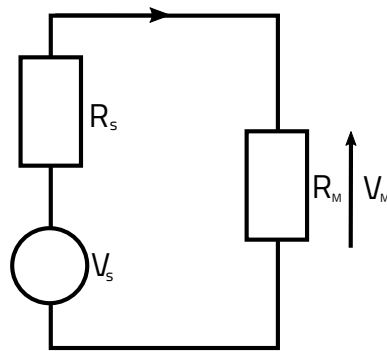

Calculating the system current to be defined as  $i = \frac{V_s}{(R_s + R_M)}$ , the voltage seen by the measurement equipment will then be  $V_M = i \cdot R_M$ . In this instance the measurement voltage will be  $-19.3$  mV, approximately half the sensor unloaded voltage.

The oxygen concentration based upon the erroneous voltage reading will be 5.257%, and not the 1% as was the case in the earlier calculation.

To ensure that voltage measurements are within 1% of the actual voltage to be measured, the instrument input impedance required can be calculated as follows:

- Sensor voltage output should be  $V = -40.380$  mV;
- 1% error on voltage to be measured,  $V_\epsilon = -0.4038$  mV;
- Impedance of sensor at 350 °C is  $R_S = 1.2\text{ M}\Omega$ ;
- Unknown required instrument impedance;

The voltage drop across the sense resistor for a 1% error in value will be  $V_\epsilon = -0.42468$  mV, therefore the current in the circuit will be:

$$i_T = \frac{V_\epsilon}{R_s}$$

To support a measurement voltage less the error at the input to the instrument, the input impedance will be defined as:

$$R_M = \frac{V_S - V_\epsilon}{i_T}$$

This translates to the measurement instrument needing an input impedance of  $R_M = 120.0M\Omega$ , which is substantially higher than that of most standard instruments.

The oxygen concentration calculated as a result of the increased input impedance, namely the measured signal, within 1% of the actual generated sensor voltage now yields an oxygen concentration of  $O_2 = 1.03\%$ . For use with standard equipment having an input impedance of  $1 M\Omega$ , the lowest operating temperature based upon the Arrhenius equation will be approximately  $600^\circ\text{C}$ .

### 10.7 Response time with respect to gas changes

Response times to changes in  $O_2$  concentration levels vary according to temperature and gas flow. And importantly the magnitude of change, namely the  $\Delta pO_2$ . Typically, we note that response times are  $0.1 \leq t \leq 0.5$  to within 90% of final stabilised voltage reading for temperatures above  $700^\circ\text{C}$ .

### 10.8 Reducing measurement noise

#### Reject DC Common-Mode voltage

Making highly accurate measurements often starts with differential readings. An ideal differential measurement device reads only the potential difference between the positive and negative terminals of its instrumentation amplifier(s). Practical devices, however, are limited in their ability to reject common-mode voltages. Common-mode voltage is the voltage common to both the positive and negative terminals of an instrumentation amplifier.

#### Reject AC Common-Mode voltage

Rarely do common-mode voltages consist of only a DC level. Most sources of common-mode voltage contain an AC component in addition to a DC offset. Noise is inevitably coupled onto a measured signal from the surrounding electromagnetic environment. This is particularly troublesome for low-level analogue signals passing through the instrumentation amplifier on a DAQ device.

Sources of AC noise may be broadly classified by their coupling mechanisms – capacitive, inductive, or radiative. Capacitive coupling results from time-varying electric fields, such as those created by nearby relays or other measurement signals. Inductive or magnetically coupled noise results from time-varying magnetic fields, such as those created by nearby machinery or motors. If the electromagnetic field source is far from the measurement circuit, such as with fluorescent lighting, the electric and magnetic field coupling is considered combined electromagnetic or radiative coupling. In all cases, a time-varying common-mode voltage is coupled onto the signal of interest, most often in the range of 50–60 Hz (power-line frequency).

An ideal measurement circuit has a perfectly balanced path to both the positive and negative terminals of an instrumentation amplifier. Such a system would completely reject any AC-coupled noise.

#### Break Ground Loops

Ground loops are arguably the most common source of noise in data acquisition systems. Proper grounding is essential for accurate measurements, yet it is a frequently misunderstood concept. A ground loop forms when two connected terminals in a circuit are at different ground potentials. This difference causes a current to flow in the interconnection, which can produce offset errors. Further complicating matters, the voltage potential between signal source ground and DAQ device ground is generally not a DC level. This results in a signal that reveals power-line frequency components in the readings.



## 10.9 Lambda Point for control

The ST Oxygen Sensor is most sensitive to changes in air/fuel mixture ratios around the lambda point of a given fuel as depicted in the generic sensor response curve given below.

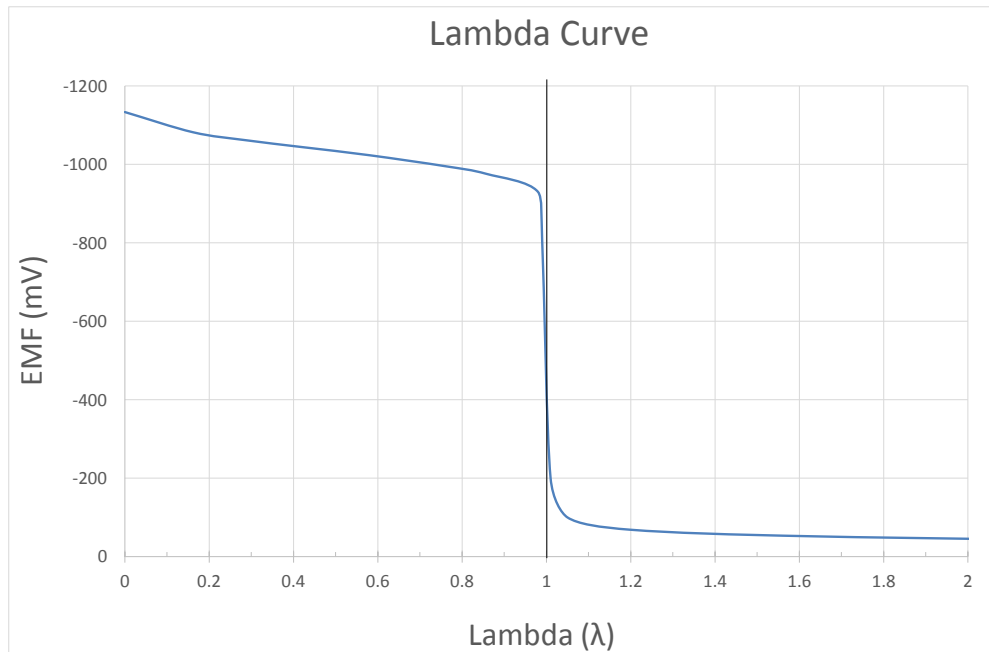

It is important to note that for non-equilibrium reacting systems the sensor coating will partially or fully complete the reaction locally. There are many variables that can influence the extent of this reaction including temperature, mixture ratios, flow rate past the sensor tip, and other reactor design factors. The ST oxygen sensor is not only well suited to carburising industries and carbon-based equilibrium systems but also responds to changes in  $O_2$  partial pressure for all gas mixtures. The sensor is accurate over a wide range of  $O_2$  partial pressures as given in the Specifications section at the front of this document.

## 11 Ordering information

When ordering the following information will need to be specified:

- The Probe length.
- The Thermocouple type.
- The required thread type.

The ST probe part number has the following format.

<b>ST - 1000 - R - NPT</b>	
<b>Thread type</b>	<b>NPT</b> for a compression fitting with a 1" NPT Thread <b>BSPT</b> for a compression fitting with a 1" BSPT Thread
<b>Thermocouple</b>	<b>R</b> for R-type thermocouple (870 - 1450°C) <b>K</b> for K-type thermocouple (95 - 1260°C) <b>S</b> for S-type thermocouple (980 - 1450°C)
<b>Probe length</b>	<b>0650</b> for 650 mm <b>0750</b> for 750 mm <b>0850</b> for 850 mm <b>1000</b> for 1000 mm <b>1200</b> for 1200 mm <b>1350</b> for 1350 mm

### Part Number Examples

**ST-0650-R-NPT** would be 650mm in length, use an R-type thermocouple and have a compression fitting with a 1" NPT Thread

**ST-1000-S-BSPT** would be 1000mm in length, use an S-type thermocouple, and have a compression fitting with a 1" BSPT Thread

**ST-1350-K-NPT** would be 1350mm in length, use a K-type thermocouple, and have a compression fitting with a 1" NPT Thread

## 12 Probe Length guide

Probe Lengths are specified from the end of the Probe head to the end of the sheath. These probes can be ordered in a range of different sizes from 650mm to 1350mm. The following lengths are standard:

- 650mm
- 750mm
- 850mm
- 1000mm
- 1200mm
- 1350mm

Custom lengths are available.

All probes come with a 4 pin XLR connector.

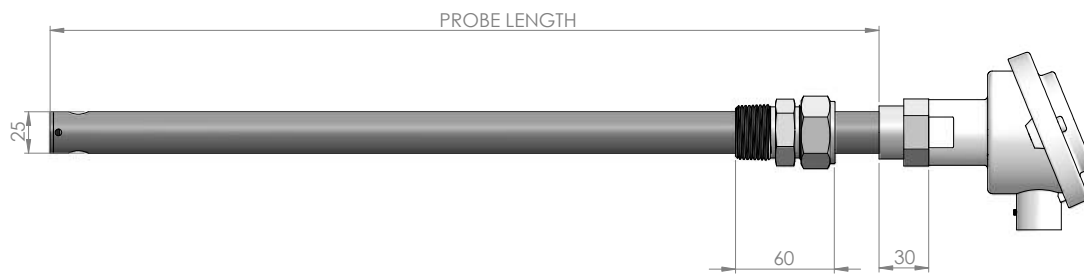

All measurements in mm unless otherwise noted.



## 13 Contact information

Australian Oxytrol Systems Pty Ltd  
85 Wood Street  
California Gully VIC 3556  
Australia

**P** + 61 3 5446 1530  
**F** + 61 3 5446 1215  
**W** [www.australianoxytrolsystems.com](http://www.australianoxytrolsystems.com)  
**E** [info@australianoxytrolsystems.com](mailto:info@australianoxytrolsystems.com)

## 14 Australian Oxytrol Systems Pty Ltd one (1) year limited warranty

### 14.1 Introduction

This is a limited warranty from Australian Oxytrol Systems Pty Ltd (as warrantor) that gives you specific legal rights.

You may also have other rights under specific consumer protection laws and regulations – if any (referred to in this warranty as “law”) of the country, state or province in which the Product was purchased (“your jurisdiction”). This warranty is governed by and subject to law and is not intended to and does not exclude, limit or suspend any rights you have under law. Some or all of the limitations or exclusions described below may not apply to you.

For the purposes of this warranty –

*AOS* means Australian Oxytrol Systems Pty Ltd (Australian Business Number 59 007 371 824).

*Product* means any AOS – branded hardware product manufactured by or for AOS and identified by the AOS trademark, trade name, or logo affixed to it.

*You* means the original end-user and retail purchaser of a AOS Product.

AOS reserves the right to make changes at any time to:

1. Product hardware and software components and specifications; and
2. Terms and conditions governing Product use, service and repair; and
3. AOS services.

Such changes are entirely at AOS’s discretion and may involve modification, upgrade, enhancement, replacement, deletion or abandonment.

### 14.2 Specific Warranty obligations

AOS warrants that its Product is free from defects in materials and workmanship under normal use for a period of one (1) year from the date of your purchase (the “*Warranty Period*”). Subject to law and the conditions set out below, if a Product is defective, AOS will decide whether to:

1. Repair the Product at no charge, using new parts or parts that are equivalent to the new in performance or reliability; or
2. Exchange the Product with either a new product or one that is equivalent to new in performance, reliability and functionality; or
3. Refund the purchase price of the product,

provided that your claim is made in accordance with this warranty and is received by AOS within the warranty period.

A replacement product or part assumes the remaining warranty of the original Product or ninety (90) days from the date of replacement or repair, whichever provides you with the longer coverage.

When a Product or part of a Product is exchanged, any replacement items become your property and the replaced item becomes AOS’s property. Parts provided by AOS in fulfillment of its warranty obligation must only be used in the Product for which warranty service is claimed.

If AOS agrees to refund the purchase price of a Product, the refund can only be paid after you have returned that Product to AOS. All returned Products become AOS’s property.

AOS does not make any representation that it will be able to repair or exchange any Product without loss of or corruption to programs and data.

### 14.3 Warranty exclusions and limitations

This limited warranty applied only to AOS Products and does not apply to any non-AOS hardware product or any software, even if packaged and sold with a AOS product. Manufacturers, suppliers, or publishers, other than AOS, may provide their own warranties to you, but AOS, in so far as permitted by law, provides itself “as is”.

#### AOS Limited Warranty

Software (including system software) and hardware distributed by AOS with or without the AOS brand name is not covered under this warranty. Refer to the licensing agreement accompanying such software for details of your rights and obligations concerning its use.

AOS is not responsible for damage arising from failure to properly follow instructions relating to the Product’s use.

This warranty does not apply to:

1. consumable parts, such as batteries, unless damage has occurred due to a defect in materials or workmanship; or
2. cosmetic damage, including but not limited to scratches, dents, and worn material on ports; or
3. damage caused by use with non-AOS products; or
4. damage caused by accident, abuse, misuse, or external causes (such as earthquake, fire or flood); or
5. damage caused by operating the product outside the permitted or intended uses described by AOS; or
6. damage caused by service (including upgrades and expansions) performed by anyone who is not a representative of AOS or a AOS authorised service provider; or
7. modifications by someone else other than AOS to alter Product functionality or capability without AOS’s written approval; or
8. any AOS Product where its serial number has been removed or defaced.

#### 14.4 Important!

Opening a hardware Product may cause damage; such damage is not covered by this warranty. Only AOS or an authorised service provider should open and perform Product service.

To the extent permitted by law:

(1) this warranty and your rights under it are exclusive and are in lieu of any other oral, written, statutory, express or implied warranties, remedies and conditions; and

(2) AOS disclaims all other warranties, including but not limited to warranties of merchantability and fitness for a particular purpose and warranties against hidden or latent defects.

If AOS cannot lawfully disclaim statutory or implied warranties then, to the extent permitted by law, all such warranties will be limited in the duration of the express warranty and to the repair or replacement service or refund as determined by AOS in its absolute discretion.

No AOS reseller, agent, or employee is authorised to make any amendment, extension, or addition to this warranty.

If any term or condition of this warranty is held to be illegal or unenforceable, the legality of the enforceability of the remaining terms and conditions will not be affected or impaired.

Except as provided in this warranty and to the maximum extent permitted by law, AOS is not responsible for direct, special, incidental or consequential damages resulting from any breach of the warranty or condition, or under any clause, category of head of claim, including but not limited to loss of use; loss of revenue; loss of actual or anticipated profits (including loss of profits on contracts); goodwill; loss of reputation; loss of damage to or corruption of data; any or indirect or consequential loss or damage howsoever caused including the replacement of equipment and property, and costs of recovering, programming or reproducing any program or data stored in or used with the AOS Product and any failure to maintain the confidentiality of data stored on the AOS product.

AOS does not authorise use of and reliance on any AOS Product in safety critical situations, where the failure of AOS Product or its compromised performance or interrupted operation could cause or contribute to personal injury or death ("potentially life threatening situations" or "PLTS"). For the avoidance of doubt out of the arising use or misuse and operation of any of its Products in such circumstances.

AOS may be prepared to assist you to undertake a risk management assessment and prepare a protocol for your use of AOS Products in the context of the PLTS, but always on the basis that all such use (including misuse) remains entirely at your risk.

It is your responsibility to identify and comply with the law governing your use of the Product applicable in each jurisdiction in which the Product is to be used.

#### 14.5 Obtaining Warranty Service

Before seeking warranty service, please first refer to AOS's online help resources identified in the Product documentation.

If the product is still not functioning properly, you should contact the AOS representatives or, if applicable, a AOS retail store, distributor or authorised service provider.

AOS will determine whether the Product requires service, and if so, AOS will advise you how, where and by whom the service will be performed.

It is important that you assist AOS to diagnose issues with your Product and that you follow AOS's warranty processes.

Service options, parts availability and response times vary according to the place in which service is requested. Please note that service options are subject to review and change by AOS at any time and AOS may restrict service to be performed in the place at which the Product was originally sold.

Upon receipt of the replacement Product or part, the original Product or part becomes the property of AOS and you agree to properly follow instructions, including if required, arranging the return of the original Product or part to AOS in a timely manner.

When providing service requiring the return of the original Product or part, AOS may require a credit card authorisation as security for the retail price of the replacement Product or part and applicable shipping costs. If you follow AOS's instructions, AOS will cancel the credit card authorisation, and you will not be charged for the Product or part and shipping costs. If you fail to return the replaced Product or part as instructed, AOS will charge your credit card for the authorised amount.

If you seek service in a country that is not the country of original purchase, you must comply with the relevant export requirements and be responsible for the payment of all duties, taxes, levies, fees and other charges including shipping and handling costs.

Where international service is available, AOS may repair or exchange defective Products and parts with comparable Products or parts that comply with local law.

AOS may require you provide proof of purchase details and or comply with registration or other requirements before providing warranty service,

AOS will collect, maintain and use your information in accordance with AOS's privacy policy.